

## **Reasoning and Argumentative Complexity\***

**Dr. Cristián Noemi**

Full Professor  
Department of Arts and Letters  
University of La Serena  
La Serena  
Chile

### **Abstract**

*The main objective of this paper is to propose a model of complexity, texture or argumentative density from the theoretical framework of text linguistics. To this effect, I have explored both the ability underlying the activity of speaking (the ἐνέργεια) as the product of this competence (the ἔργον). From the first perspective, some cognitive operations involved in this knowledge during the activity of discursive production are suggested which, as has been proposed, are projected onto the discourse in the form of more or less discourse complexity, texture or density. From the second, a normative model of the level of complexity of the product is proposed on the basis of the relational texture of the propositions and on the notion resulting of argumentative coherence.*

**Keywords:** Argumentative complexity, critical thinking, argumentation, discourse.

\*This work is sponsored by the National Commission for Scientific and Technological Research of the Chilean government, FONDECYT project N<sup>o</sup> 1130584

### **1. Purpose**

The objective of this work is to propose a discursive model of complexity, texture or argumentative density within the theoretical framework of text linguistics. To this effect, the ability underlying the activity of speaking (ἐνέργεια) and the product resulting from this competence (ἔργον) have been explored. For the former, some cognitive operations that may be related to the production of discourse are suggested. Such operations, as has been proposed, are projected onto the text with low or high levels of complexity, texture or density. For the latter, a normative model for discourse complexity, based on the relational texture of discourse propositions and the notion resulting of argumentative coherence, is proposed. This work puts forward the hypothesis that the ability of critical thinking (reasoning/ἐνέργεια) is related to the formal argumentative complexity of discourse (ἔργον). In order to explore the nature of domain of both capacity (ἐνέργεια) and product (ἔργον), this work seeks to determine the possible relationship between the capacity or level of critical thinking and the level or degree of discourse complexity among college students.

### **2. Methodology**

This work has followed a combined qualitative and quantitative approach. In order to determine the capacity or level of critical thinking, 80 college students were tested by means of the *Tasks in Critical Thinking* test, elaborated by the Educational Testing Service from Unites States. Consisting of 15 questions of analytic type, this test considers, on the one hand, the multidimensionality of critical thinking and, on the other, the prior cognitive skills. It also considers three dimensions: inquiry, communication and analysis. In order to determine the degree of argumentative complexity of individuals, a qualitative approach based on the principles of grounded theory was used. Data were processed using ATLAS. ti software.

### **3. Theoretical Approach**

#### **3.1. Thought and language**

The perception of a rather continual boundary between the notions of reasoning and language can be traced back from Aristotle, when he argued that: “And just as written words are not the same for everyone, neither are spoken ones the same. However, what these are primarily signs of (*sêmaia*), namely the affections are likenesses of (*homiômata*), namely real beings, are also the same.” (Aristotle, 2013:1.5), to Wittgenstein, who stated that: “In a proposition a thought finds an expression that can be perceived by the senses.” (Wittgenstein, 1960:3.1); and “A propositional sign, applied and thought out, is a thought.” (Wittgenstein, 1960: 3.5). Contemporary cognitive psychology studies nevertheless have shown that language is not just a cognitive capacity of human beings, but also a module which shares functions with, at least, perception, memory, intelligence and thought; i.e., a number of specialized and relatively autonomous subsystems interacting with each other to some extent. Thus, it has been proposed that language is a cognitive module (Fodor, 1983), therefore, its mode of operation would not be directly affected by the other components of cognition. Within this framework and based on evidence such as the discovery of the FOXP2 protein on the chromosome 7 (Fisher and Vernes, 2015), it has been stated that language would be a specific ability which does not depend on other cognitive activities.

##### **3.1.1. Natural reasoning and language**

Developmental psychology has reported that during the first years of life (phase of absolute realism), human beings assume that mental representations of reality correspond exactly to reality itself. As a result of the development of both cognitive functions and personality traits, the function of met cognition emerged along with a certain degree of reflexive capacity that allows the production and assessment of arguments. As reflexive thinking is of met cognitive nature, it can occur only when the mental content has been symbolically registered, which in turn occurs when language development allows building and representing concepts. When these concepts interrelate to reach a conclusion, a sort of arguments (expressions of the mental activity which may or may not be verbally formalized) is constructed. According to Mercier and Sperber (2009), I admit that the arguments used in reasoning are the output of the mental mechanism of inference. The function of reasoning is thus conceived as an argumentative mental activity since it involves an activity of conceptual inference that leads not only to a new mental representation (or conclusion) but also to collateral representations (or premises) that provide guarantees to accept the largest representation. Thus, reasoning can then be conceived as the mental activity that allows producing a convincing argument as well as assessing and accepting a conclusion reached by another individual.

##### **3.1.2. Reasoning and critical thinking**

Critical thinking has basically been addressed from three perspectives. First, from a philosophical approach (Siegel, 2013), which focuses on the quality of thought, in terms of a set of standards or rules, i.e., accuracy, clarity, fairness, precision, logic, breadth, relevance, etc., that an individual has to achieve to be considered a critical thinker. Second, from cognitive psychology principles (Halpern, 2006), which focus primarily on the phases regarding the processing of information carried out by a critical thinker (e.g. analysis, interpretation, problem definition, hypothesis formulation, etc.). Third, from a pedagogical perspective (Bloom, 1971), in which cognitive abilities are hierarchically classified in a gradual taxonomy.

#### **3.2. Argumentative complexity**

Speech complexity has superficially been addressed from different theoretical approaches, mainly focused on the microstructure of the text, particular in its syntactic organization. Véliz (1998; 1999), for instance, relates the syntactic maturity with the ability to produce structurally complex linguistic units at a sentence level, which would be expressed in the number of combinations and transformations that a speaker makes when producing a given sentence. From a different epistemic approach, van Eemeren, Grootendorst and Snoeck (2006), when differentiating simple versus complex, multiple, coordinated or subordinated types of argumentation, propose a model in which argumentative complexity is considered in terms of the number of and relations between arguments. In a larger semiotic context and based on Beaugrande (1997)'s standards of textuality, Merlini (2011) considers textual complexity as an evidence of *markedness*, suggesting that complexity emerges whenever text sequences present less natural or more marked choices, thus affecting cohesion, coherence, intentionality, acceptability, etc.

### 3.2.1. Argumentative complexity as ἐνέργεια

I use the concept of argumentative complexity to refer to the body of knowledge that a speaker possesses and uses to argumentatively organize, through different degrees of texture or density, a speech at a macro structural level. Considering discourse capacity as a competence, it is interesting to establish the type of knowledge involved in critical reasoning/thinking and used to discursively unfold the macrostructure of a text, at different levels of complexity, by means of a set of sequential propositions of lower level. Contrary to the macro rules proposed by van Dijk (1980), I suggest the notions of attachment, particularization and specification as production rules that may determine density, texture or complexity of discourse. The ‘attachment’ rule represents the inverse operation to the ‘omission’ van Dijk’s macro rule. Here, the macro proposition (<Mpa>) is unfolded in a series of smaller propositions (<Pc>, <Pd>, <Pn>) within the discourse macrostructure. In this operation, speech can be wrapped with a series of propositions which, as they are not relevant to the macrostructure, should be placed at a low depth of the macrostructure.

The ‘particularization’ rule implies the inverse operation to the ‘generalization’ van Dijk’s rule. In this case, the macro proposition (<Mpb>) is rewritten in a series of minor propositions (<Pb1>, <Pb2>, <Pb3>). Thus, the macro proposition can be split up into a series of propositions. As a textualization rule, it apparently has a higher density, texture or complexity than the attachment rule. Finally, the ‘specification’ rule represents the inverse operation to the ‘integration’ van Dijk’s macro rule. Through its implementation, a macro proposition corresponding to a cultural frame (<Mp frame>) is unfolded in a series of propositions subsumed under the same frame (<Pa frame>, <Pb frame>, <Pn frame>). By applying this rule, discourse can be created in terms of propositions within the same macrostructure cultural framework.

### 3.2.2. Argumentative complexity as ἔργον

I conceive that the linguistic competence consists of different types of knowledge (Coseriu, 1992) which are necessarily interconnected while being updated in the form of a particular discourse. Constrained by the influence of the discursive tradition, such competence is projected unevenly in the form of discourse, affecting the density, texture or complexity of the macrostructure (van Dijk, 1980) and, therefore, the degree of coherence. I use the term coherence to refer to the interrelatedness (macrostructure) of the text (Halliday and Hasan, 1976; Shapiro and Hudson, 1991) that depends on the formal structure and the relations established by its constituents. It should be noted that these relations are nonlinear and can be established at different levels of discourse depth (van Dijk and Kintsch, 1983). Discourse, in this sense, constitutes a set of relations in which its constituents act as markers or indicators that determine the density, texture or complexity of the macrostructure (Calsamiglia and Tusón, 2002). Depending on the quality (or degree) of the critical thinking variables that a speaker may possess or activate, a certain type of discourse will be updated at a high or low level of coherence that will be determined by its textual structure and the relations among its parts. This can be measured in terms of complexity or texture density of the discourse framework. In this sense, I propose the following markers (see Fig. 1) of argumentative complexity (Noemi, 2013; Noemi, 2014):

- 1 - The number of propositions (p) per sequence
- 2 - The number of support per sequence (p2)
- 3 - The number of explain per sequence (p3)
- 4 - The number of justify per sequence (p4)
- 5 - The level of macro structural depth
- 6 - The number of binding to pos
- 7 - The epistemic nature of to pos

Proposition (p) represents the semantic content of a sentence and, therefore, constitutes the lowest level of the macrostructure. It is associated with the attachment rule and the communication dimension of the critical thinking test. Support represents an argumentative nexus to (p). It implies a greater cognitive effort by a speaker and is probably associated with higher levels of critical thinking. Explain represents an explanation drawn from the discursive world generated by (p) and endorsed by support. It also implies a greater cognitive effort which, together with support, might be associated with the inquiry dimension measured by the critical thinking test. Justify finally represents a justification drawn from the discursive world generated by (p), support (p2) and explain (p3). It implies greater cognitive effort and is associated with the inquiry dimension measured by the critical thinking test.

### 3.2.2.1. Topos

In the work of Aristotle (1990), as well as in the doctrinal corpus of almost all the classical rhetorical theory, there is a category originally addressed under the concept of *topica*. In Aristotle's view, *topoi* are *said* by means of dialectical and rhetorical syllogisms, which add, in the opinion of Billig (1988), a moral quality to speech acts since socially sanctioned sense agreements are referred. Aristotle (1990) distinguishes between the major and minor *topica*. The former, on the one hand, goes through any discourse regardless of its subject. Thus, *topoi* such as the most/least, the possible/impossible, which happened/did not happen, can be found in every discourse. The latter, on the other, deals with all those *topoi* that would be appropriate in the context of a specific science. In a similar epistemic line, Perelman and Olberchts-Tyteca (1989) suggests that when speakers try to support values or strengthen the intensity of discourse, they can resort to general premises which, according to the orthodox tradition, are also considered as *topoi*.

Regarding the argumentative potential of language, Ducrot (1986) proposes two types of *topoi*, intrinsic and extrinsic. The former is related to the structure of language and, therefore, is manifested in grammatical words (relational). The latter (closer to the classic conception of the concept) ensures the connection between the statements by providing a nexus with a certain ethic and in a particular social context. In his opinion, these extrinsic *topoi* are related to ideological principles which are shared by a relatively large linguistic community and presented as external to the speaker while used for the construction of arbitrary ideological representations.

Rigotti (2006), on the other hand, provides otherwise an approach integrated to the notion of *topos* in the context of a partial theory of language. In his opinion, the *topos* is part of the argumentative strategy module and functions as a generator of utterances.

My interest has been focused on describing the role that the category of *topos* plays in the dynamics of texture and complexity of discourse. From this perspective, the *topos* acts as a support, a sort of *anchor*, in the macrostructure argumentative framework (Fig. 2). This approach conceives *topoi* as an element which is part of the speaker's competence and internalized and shared throughout socialization processes. Thus, when a speaker learns a language not only acquires a set of grammar rules but also a system of values referring to mechanisms for the representation of reality. Given its potential to objectify the system of values, the *topoi* are the basis of argumentation. As a marker of values, the *topoi* functions as a binding element that can be recognized as a marker of textual coherence, since they give the reason, i.e., endorse, support and reinforce. In other words, they contribute to discourse density and texture, and, consequently, to the coherence of an argumentative discourse.

### 3.2.2.2. Axiological axis

From Aristotle (2006), and depending on the type of discourse, three axiological axes are distinguished: cardinal, theological and pragmatic. The notion of axiological axis refers to the fundamental domain of the different types of values which are expressed in a particular discourse. The cardinal axis has been named after the four cardinals, or primary, virtues: prudence, strength, humility and tolerance (Aristotle, 2006). The theological axis takes its name from the virtues hold by Christianity: faith, hope and charity. Finally, the pragmatic axis takes its name from the so-called pragmatic logos (Aristotle, 2013) and is based on action, as opposed to the apophantic logos, which is more common in science and is based on the primacy of propositional logic.

## 4. Findings

In order to show the now unveiled relationship between the capacity or degree of reasoning and the degree or argumentative complexity, two prototypical examples of the general tendency of the corpus, along with their respective scores for the critical thinking and argumentation complexity dimensions, are presented (Table 1, Fig.3; Table 2, Fig.4). Individual 1, shown in Table 3, categorized as deficient in critical thinking after obtaining a total score of 17 points, 8 points in analysis, 5 points in inquiry, and a normal performance in communication, through the cognitive operations that I have called 'macro rules of density, texture or argumentative complexity', produces an descriptive-argumentative type of discourse containing 11propositions (p) at the base, supported by 10(p2) at the next level of macro structural depth (see Fig. 3).

In terms of discursive strategy (Fig.3), it was observed, on the one hand, that some (p) are supported by more than one (p2), and, on the other, that the binding *topos* is causal; thus, the individual can be epistemic ally placed in the pragmatic axis. According to this proposal, the text produced demonstrates low critical thinking and, therefore, low coherence due to the weak framework or discursive density represented by the low macro structural depth and the absence of significant relations among propositions.

Individual 2, as show the Table 4, categorized as high in terms of critical thinking, achieving a total score of 31 points, 12 in the category of analysis, 14 in inquiry and a high performance in the communication, by the macrorules of density, texture or argumentation complexity generates an descriptive-argumentative discourse containing 3(p) at the base, supported by 4 (p2) at the second level of complexity (labeled as support) (see Table 4). In contrast to individual 1, individual 2 shows more discourse density as moving forward to the second level of macro-structural complexity (labeled as explain) by using more complex cognitive macrorules, thus ensuring a greater coherence due to this level of texture. Indeed, the 4 (p2) are supported by 7 (p3) which, in turn, establish different relationships as shown in Fig.4. Individual 2 applies macrorules of a greater cognitive range until reaching the third level of density or argumentative complexity labeled as justify which, in terms of texture, represents a considerable degree of complexity and coherence. Finally, individual 2 uses binding topoi of causal and explanatory nature. Thus, he can also be epistemic ally placed within the pragmatic axis.

## 5. Conclusion

This work has initially allowed propose certain cognitive operations associated with language proficiency, i.e. attachment, particularization and specification, whose role, as has been suggested, is to unfold, in terms of *ἐνέργεια*, the textual macrostructure at different degrees of discourse density, texture or complexity. In a similar sense, data allowed to build a model of argumentative complexity which, as *ἔργον*, has intended to determine the different degrees of discourse texture or density at a macrostructure level. The cross between the data provided by the Tasks in Critical Thinking test and the information obtained from the model of argumentative complexity has allowed specify certain aspects about the relationship between reasoning and language, particularly, about the domains characterizing these cognition modules.

From the sample under analysis, it is possible to suggest that there is a relation between (critical) reasoning and argumentative complexity. As for the cognitive dimensions quantitatively measured, analysis and synthesis present the greatest relations with argumentative complexity. Thus, it can be established that individuals presenting a high or very high argumentative complexity have a high or very high level of critical thinking.

The inverse association is not possible to establish. Apparently, it is easier to acquire critical thinking than to unfold it in the form of discourse. The textualisation operation, in other words, involve other variables that have not been covered in this research. This study also allowed to isolate a function of topoi that has not been mentioned in the literature and, as has been shown, that plays the formal role of binding the levels of the macrostructure, thus contributing to discourse density, texture or argumentative complexity, and, therefore, to semantic coherence. Finally, the results suggest that the model of argumentative complexity constitutes a valid instrument for discourse analysis.

## 6. References

- Aristotle. (2013). *Perihermeneias*. The University of Adelaide Library.
- Aristóteles. (1990). *Retórica*. Madrid: Centro de Estudios Constitucionales.
- Aristóteles. (2006). *Ética a Nicómaco*. Buenos Aires: Gradifco.
- Beugrande, R. (1997). *Introducción a la lingüística del texto*. Barcelona: Ariel.
- Billig, M. (1988). Common-places of the British Royal Family: a rhetorical analysis of plain and argumentative sense. *Text* 8, (3), 191-217.
- Bloom, B. (1971). *Taxonomía de los objetivos de la educación: la clasificación de las metas educacionales: manuales I y II*. Buenos Aires: Centro Regional de Ayuda Técnica: Agencia para el Desarrollo Internacional.
- Calsamiglia, H. & Tusón, A. (2002). *Las cosas del decir: manual de análisis del discurso*. Barcelona: Ariel.
- Coseriu, E. (1992). *Competencia lingüística*. Elementos de la teoría del hablar. Madrid: Gredos.
- Ducrot, O. 1986. *El decir y lo dicho. Polifonía de la enunciación*. Barcelona: Ediciones Paidós.
- Fisher, S. & Vernes, S. (2015). Genetics and the Language Sciences. *Annual Review of Linguistics*, 1, 289-310.
- Fodor, J. (1983). *The modularity of mind*. Cambridge MA: MIT Press.
- Halliday, M. & Hasan, R. (1976). *Cohesion in English*. London: Longman.
- Halpern, D. (2006). The nature and nurture of critical thinking. In, R. Sternberg, R. Roediger, & D. Halpern (Eds.), *Critical Thinking in Psychology*, (pp.1-14). Cambridge, MA: Cambridge University Press.

Mercier, H. & Sperber, D. (2009). Intuitive and reflective inferences. In, J. Evans & K. Frankish (Eds.), *Two Minds*, (pp.149-170). Oxford: Oxford University Press.

Merlini, L. (2011). A 'natural' approach to text complexity. *Poznań Studies in Contemporary Linguistics*, 47(2), 203-236.

Noemi, C. (2013). Aproximación teórica a la noción de complejidad argumentativa. *Logos: revista de lingüística, filosofía y literatura*, 23, 256-271.

Noemi, C. (2014). Un modelo de representación de complejidad argumentativa: el discurso de Friedman. *Linguagemem (Dis) curso*, 14 (2), 305-320.

Perelman, Ch. & Olbrechts-Tyteca, L. (1989). *Tratado de la argumentación. La nueva retórica*. Madrid: Gredos.

Rigotti, E. (2006). Relevance of context-bound loci to topical potential in the argumentation stage. *Argumentation*, 20 (4), 519-540.

Shapiro, L. & Hudson, J. (1991). Children's scripts, stories, and personal narratives. In, A. McCabe & C. Peterson (Eds.), *Developing narrative structure*, (pp.89-136). New Jersey: Lawrence Erlbaum Associates.

Siegel, H. (2013). Elpensamiento crítico como un ideal educacional. *Logos: revista de lingüística, filosofía y literatura*, 23, 272-292.

VanDijk, T. (1980). *Macrostructures. An Interdisciplinary Study of Global Structures in Discourse, Interaction, and Cognition*. Hillsdale, New Jersey: Lawrence Erlbaum Associates Publishers.

VanDijk, T. & Kintsch, W. (1983). *Strategies of discourse comprehension*. New York: Academic Press.

VanEemeren, F., Grootendorst, R. & Snoeck, F. (2006). *Argumentación: análisis, evaluación, presentación*. Buenos Aires: Biblos.

Véliz, M. (1988). Evaluación de la madurez sintáctica en el discurso escrito. *RLA. Revista de Lingüística Teórica y Aplicada*, 26, 105-141.

Véliz, M. (1999). Complejidad sintáctica y modo del discurso. *Estudios Filológicos*, 34, 181-192.

Wittgenstein, L. (1960). *Tractatuslogico-philosophicus*. London: Routledge & Kegan Paul Ltd.

7. Figures and Tables

Fig. 1: Levels of argumentative complexity

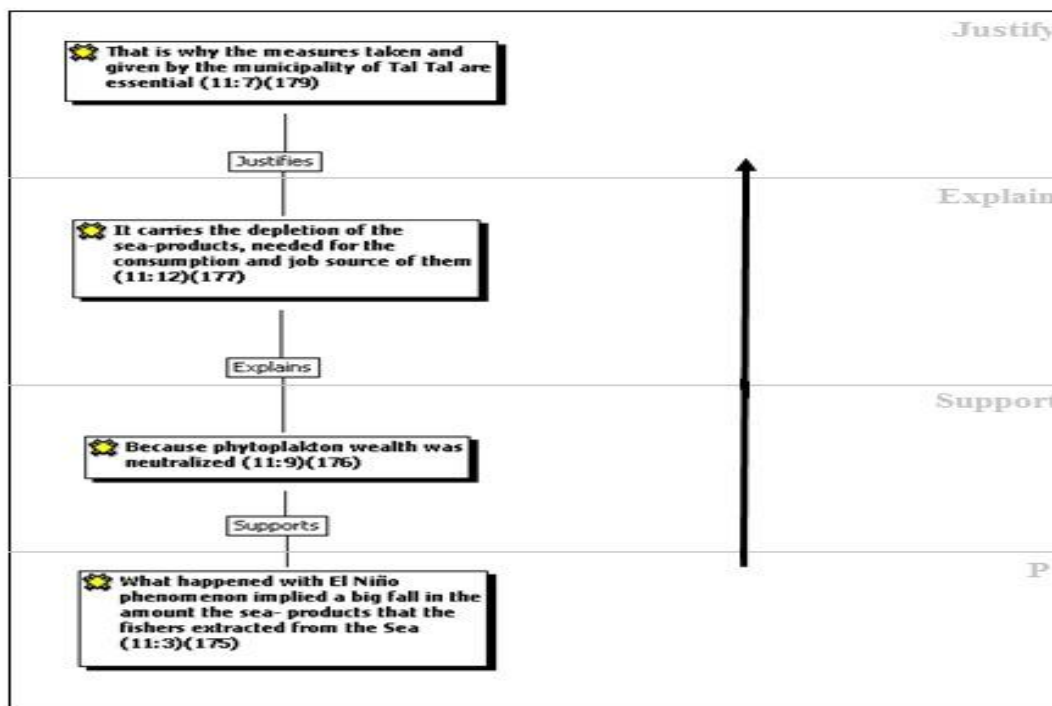

Fig. 2: Basic anchoring

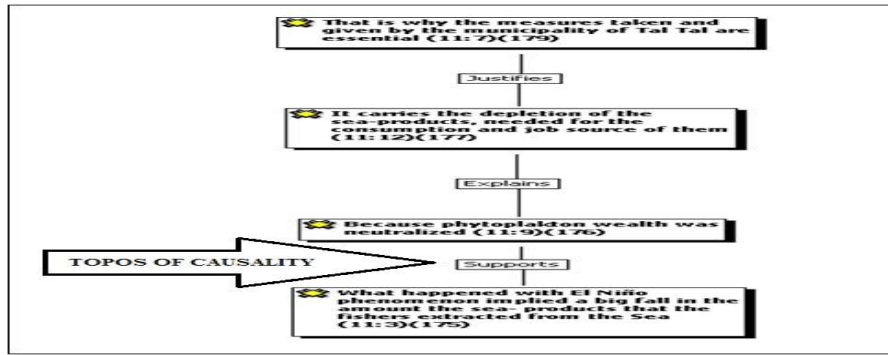

Fig.3: Discourse complexity: Individual 1

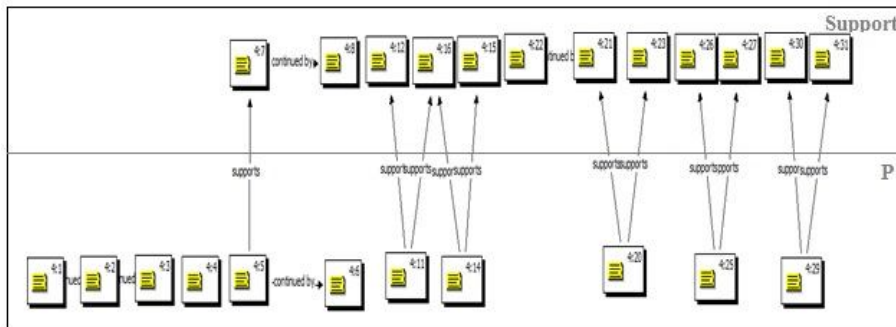

Fig. 4: Discourse complexity: Individual 2

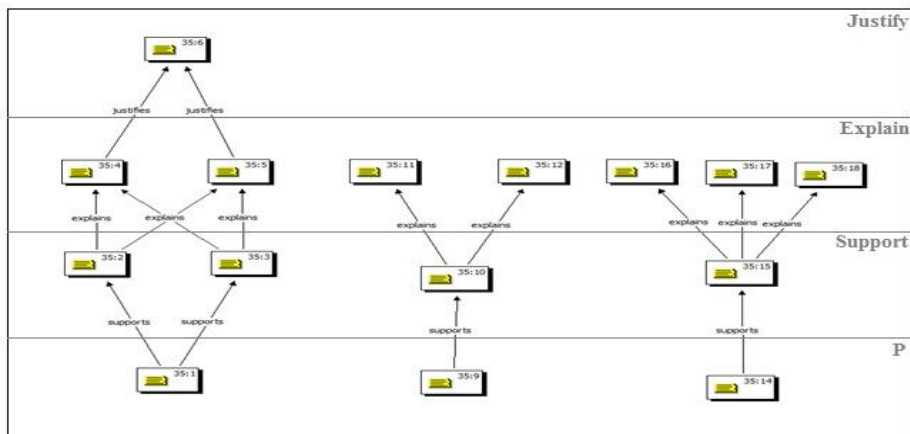

Table 1: Critical thinking dimension: Individual 1

Critical thinking	Deficient
Total score	17 pts.
Analysis category	8 pts.
Inquiry category	5 pts.
Communication category	Normal

Table 2: Critical thinking dimension: Individual 2

Critical thinking category	High
Total score	31 pts.
Analysis category	12 pts.
Inquiry category	14 pts.
Communication category	High